



C57T Overhead Electric

Features:

The SKC57T overhead electric cassetted blind comes with a 230v AC Tubular Motor as standard. At the touch of a button from the remote switch (sold separately), the blind can open and close, shading ceiling windows with ease. This blind is quietly drawn across the window by tensioned spring units. Fabric is neatly held in place and remains taut by the side channels. The powder-coated aluminium headbox provides a discreet and stylish solution for overhead shading. The C57T can be made to a maximum size of 3m X 3m.

Benefits:

The SKC57T provides absolute control over the blind at the touch of a button due to the single channel hand held transmitter, making this blind easy to operate in otherwise difficult areas. The discreet and slim powder-coated aluminium headbox allows the blind to blend in with the interior design of the room whilst providing the shading solution required. This blind is bracket less which eliminates room for light-seepage and is simpler to install in comparison to other overhead blinds.

Options:

Black or white hardware, hard-wired or RTS motor. It is recommended that only the following fabrics are used in conjunction with this product: Medway, Roach, Roe.

Specification:

The SKC57-90/120T electric overhead cassetted blind with Tracker Fabric Retaining System. Flame retardant fabric from the YewdaleDefiant® range, on a grooved 53/70mm aluminium barrel along with aluminium bottom bar as standard. The barrel, driven by a 230v AC motor, operates the blind by means of tensioned spring units connected to the bottom bar. Twin black/white powder-coated aluminium headbox cassettes, side and bottom channels and bottom bar.

Cassetted Blind Profile Dimension Guide

Model	Cassette Size (HxD)	Barrel Size Ø	Side Channel Size (WxD)
C57-90T	105 x 95mm	53mm	50 x 24.8mm
C57-120T	140 x 120mm	53 / 70mm	50 x 24.8mm

Some rippling may occur at the edges of the fabric.

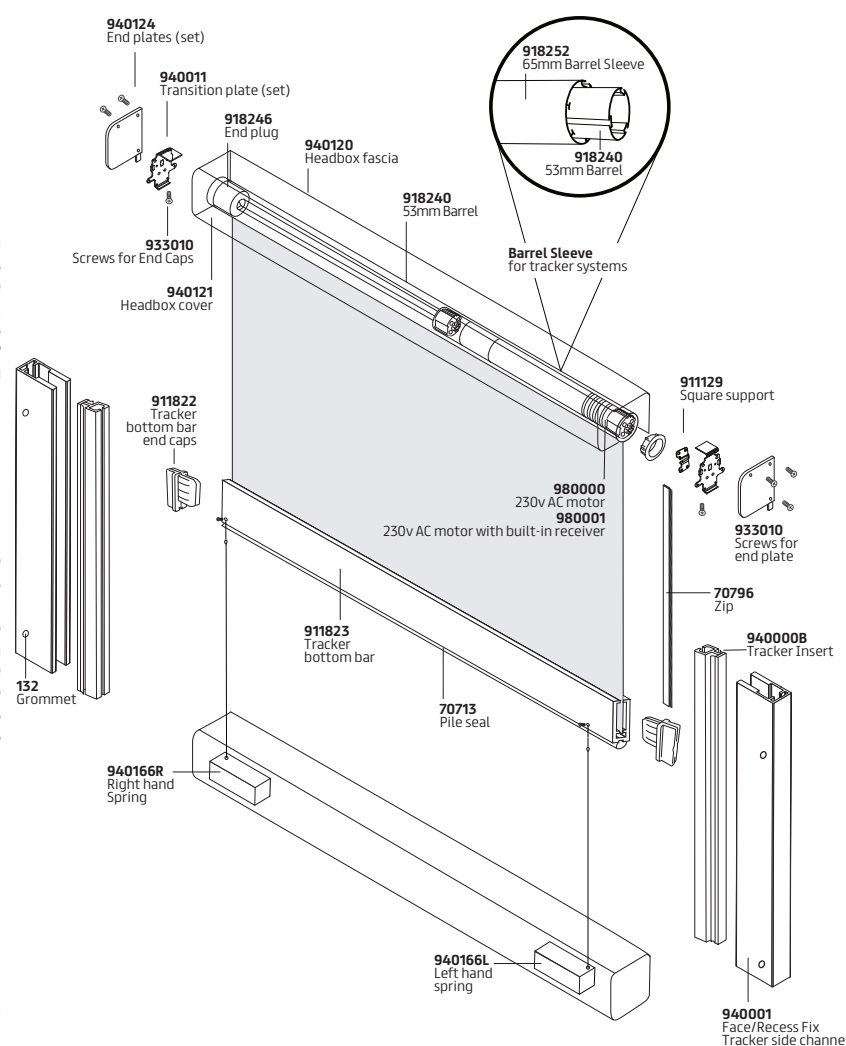

Find this product
on NBS Source