

SKC47 Electric 230v

Features:

The SKC47 electric cassetted blind with side channels features a motor as standard. The cassette is designed for top or face fix and accommodates a 40mm grooved aluminium barrel, housing the 230v AC motor. The motor is controlled by a switch which may be surface or flush mounted (not supplied as standard). Fabric is locked into a groove in the barrel with studs fitted at the edge of the fabric to retain it within the side channels. Aluminium bottom bar. Black or white hardware as standard.

Benefits:

The C47 offers a premium electric operated cassetted blind for situations where durability and functionality are required. Its quiet and reliable motor is housed within the barrel and further protected by the robust aluminium head-box housing. The fabric is locked into the barrel and bottom bar and will give years of trouble-free use. It is located in the groove so that it may be slid out sideways for easy repair or replacement of blind cover.

Options:

Black or white hardware; Remote and/or group control systems in place of single switch; Tracker fabric retaining system; Available in any RAL colour.

Specification:

The SKC47-90/120 electric cassetted blind with side channels. Flame retardant fabric from the YewdaleDefiant® range, locked into grooved 53/70mm aluminium barrel along with aluminium bottom bar as standard. 230v AC motor is housed within black/white aluminium cassette with side channels and bottom bar.

Please note: caution should be used when installing in drafty conditions - blinds should not be left down in the situation of open windows.

Cassette Blind Profile Dimension Guide

Model	Cassette Size (HxD)	Barrel Size Ø	Side Channel Size (WxD)
C47-90	105 x 95mm	53mm	55 x 13mm
C47-120	140 x 120mm	53 / 70mm	55 x 13mm

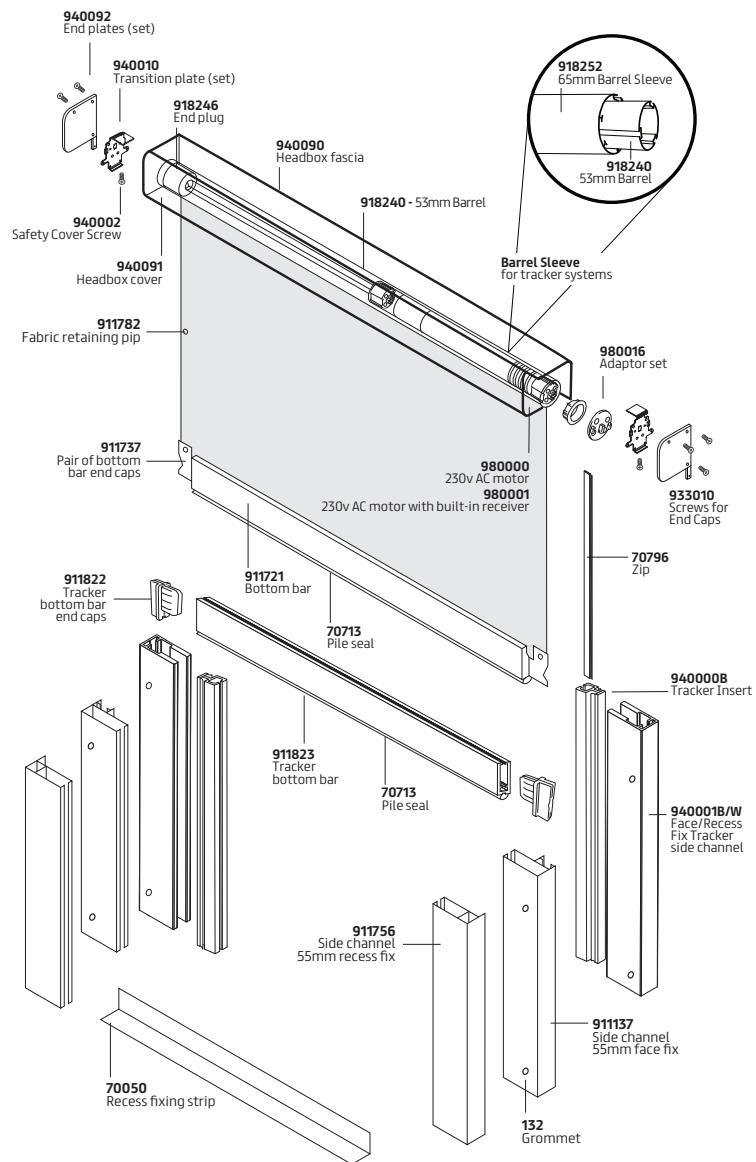

Find this product on NBS Source



This product range comes with a full Lifetime Warranty as standard.